

Product data sheet

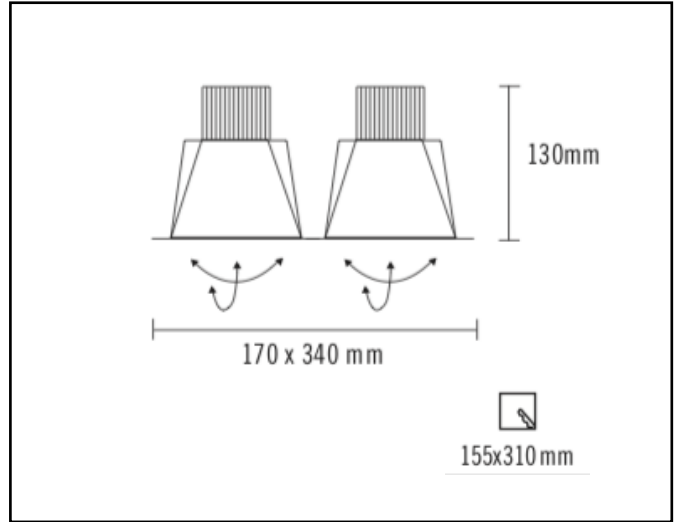

INOX-L DOUBLE SQUARE

2x12w – 2x33W 2x1500lm – 2x4000lm 15° - 70°



Description	Recessed, orientable accent spot
Dimensions (mm)	170mm x 340mm x 130mm
Weight (kg)	1,700 kg
Housing	Painted die-cast aluminium
Colour	White, black, silver
Optical system	Facetted reflector
Lighting Distribution	15° - 70° rotanional symmetric
Unified Glare Ratio	<22
Colour temperature (K)	2700K – 4000K
CRI (Ra)	> 80 / > 90
SCDM	3
Net lumen output (25°C)	2x1500lm – 2x4000lm
Efficacy – LOR (lm/W)	114lm/W – 125lm/W
Power (driver incl.)	2x12W – 2x33W
Driver	Separate box included
IP	IP 42
IK	IK 02
Lifetime (hours)	50.000 hours L80 B20
Warranty	5 years
Origin	Spain
Norms	LVD 2006/95/EC EMC 2004/108/EC RoHS 2001/65/EC

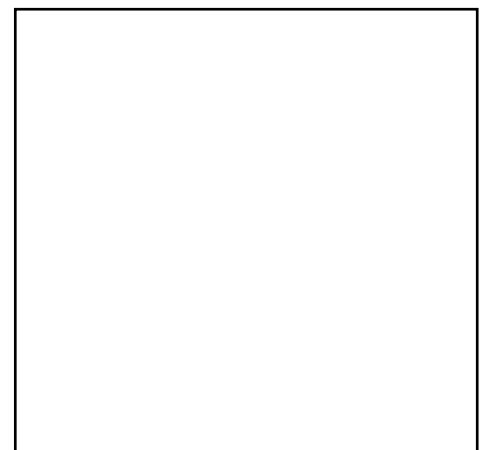
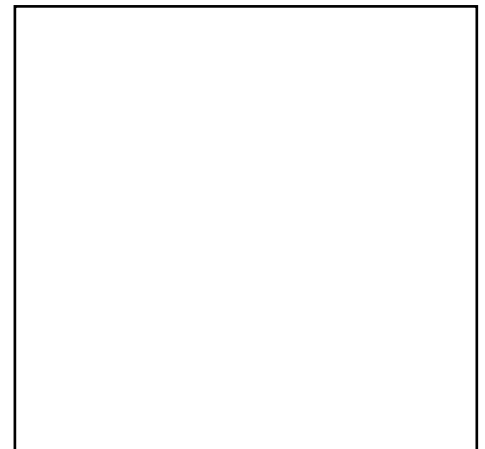

All specifications, descriptions and images are purely informative, not binding and subject to errors and changes

Euro-Luce Light Engineering
Ballingsweg 25 – 9620 Zottegem
info@euro-luce.be
www.euro-luce.be
Tel 0032 54 55 71 10

Marks

